

T88

Type T88 (R) Temperature Regulating Valves

For liquid, gas

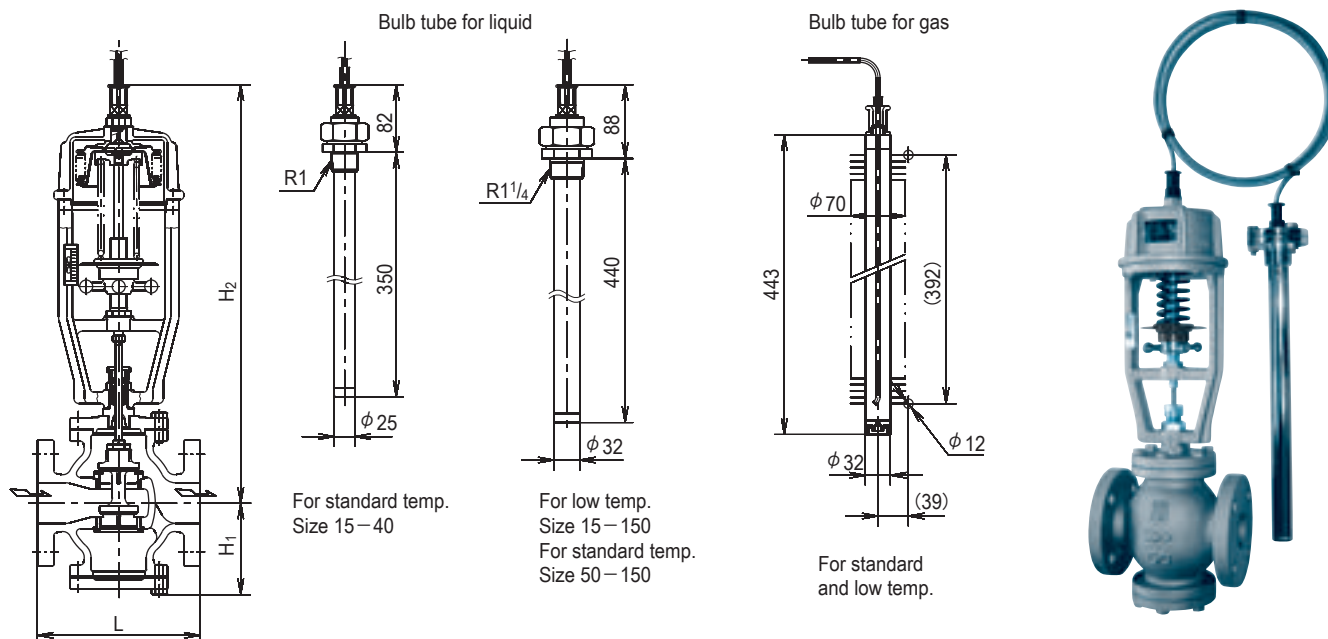

5

Temperature Regulating Valves

Specifications

Type	For heating : T88 For cooling : T88R											
Set temperature range	15-120°C ⁽¹⁾											
Size ⁽²⁾	15	20	25	32	40	50	65	80	100	125	150	
Valve	Double seat (Normal flow : for heating, Reverse flow : for cooling)											
Seat leakage	0.5 % of rated flow or less											
Max. allowable pressure (MPa)	1.0				0.7				0.5		0.2	
Connection	Flanged JIS10K FF											
Fluid through valve	Steam (max. 185°C), Water (min. 0°C)											
Bulb tube pressure (MPa)	1.0											
Bulb tube connection	Screwed											
Capillary tube	3m (max. 5m)											

Note⁽¹⁾ : Refer to table of standard set temperature range.

Note⁽²⁾ : T88S is recommended for size 15-25.

Main parts material

Part name	Material
Body	Cast iron ⁽³⁾
Cover	Bronze, bass for size 15-40, cast iron for size 50-150
Valve disc	Stainless steel
Valve seat	Stainless steel
Yoke	Cast iron
Bellows	Phosphor bronze
Capillary tube	Copper tube covered by bellows
Bulb tube	Stainless steel tube

Note⁽³⁾ : Cast steel body and stainless cast steel body are available on request.

Remarks 1. Flange connection for bulb tube is available

2. In case bulb tube for gas is pressurized, please specify it.

Construction and Cv values

(mm, kg)

Class \ Size	15	20	25	32	40	50	65	80	100	125	150
L	140	145	160	180	195	200	220	240	280	370	450
H ₁	73	73	78	86	98	113	118	138	151	178	208
H ₂	465	465	475	480	490	515	521	568	581	607	637
Top diameter	160	160	160	160	160	160	160	180	180	180	180
Weight	12	13	15	19	21	30	32	40	57	98	130
Cv	4	4	7	10	13	20	22	32	47	100	110

Type T88 (R) Temperature Regulating Valves

Standard set temperature range

Category	Class	Set temperature range	Max. allowable temperature
Low temperature	No. 1	15°C – 30°C	45°C
	No. 2	20°C – 40°C	50°C
	No. 3	35°C – 55°C	70°C
Standard temperature	No. 4	40°C – 60°C	70°C
	No. 5	50°C – 70°C	80°C
	No. 6	60°C – 80°C	90°C
	No. 7	70°C – 90°C	100°C
	No. 8	80°C – 100°C	110°C
	No. 9	90°C – 110°C	120°C
	No.10	100°C – 120°C	130°C

Temperature error

Class	For liquid		For gas	
	Standard temp.	Low temp.	Standard temp.	Low temp.
Connecting tube : 3m	Max. 4.5°C	Max. 5°C	Max. 7°C	Max. 8°C

Sizing

Use the following chart to select the suitable valve size.

Example

Fluid : saturated steam

Inlet pressure : 0.53MPa

Flow : 300kg/h

Allowable differential pressure : 0.1MPa

From saturated temperature of outlet pressure 0.53 – 0.1 = 0.43MPa, draw a horizontal line right to 300kg/h steam flow line.

From there, draw a vertical line upward to 0.1MPa differential pressure.

As the final intersecting point is between 20 line and 25 line, the required valve size is 25.

