

Direct acting

# Type PPD41B-2 Pressure Reducing Valves

For liquid

- Negligible influence is exerted by inlet pressure change due to the use of a pressure balancing construction.
- A valve disc made of synthetic rubber prevents seat leakage
- Built-in strainer (50 mesh)



1 Pressure Reducing Valves (For liquid)

## Specifications

Fluid	Pressure (MPa)		Temp. (°C)	Material for main parts					Connection
	Inlet	Outlet set range		Body	Bottom cover	Spring case	Valve disc	Diaphragm	
Oil & non-corrosive gases	0.05	0.03-0.15	0	Bronze	Bronze	Cast iron	Stainless steel & synthetic rubber	Synthetic rubber	Screwed JIS Rc
Pure water	1.0	0.1-0.7	80	Stainless cast steel	Stainless steel		Stainless steel & Teflon	Teflon seated synthetic rubber	Flanged JIS10KFF

## Performance

Min. differential pressure	0.02MPa
Lockup pressure	Max. 0.02MPa (Max. 0.03MPa for Teflon disc)
Offset	10% of max. set range (min. 0.05MPa) or less
Min. controllable flow rate (water) <sup>(1)</sup>	1 ℓ/min (2 ℓ/min for Teflon disc).
Seat leakage	Nil (0.05% of rated flow or less for Teflon disc)
Max. usable viscosity	200mm <sup>2</sup> /s (at operating temp.) <sup>(2)</sup>

Note <sup>(1)</sup> : Except for water, the flow rate should be divided by  $\sqrt{\gamma}$  ( $\gamma$  : sp.gr., water (4°C) : 1).  
<sup>(2)</sup> : When viscosity is over 20mm<sup>2</sup>/s, flow rate should be corrected.

Flow characteristic curve

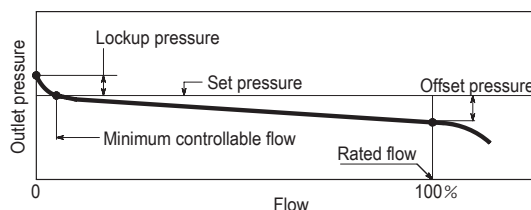

## Cv values

Size	15	20	25
Cv	1.8	2.6	3.9
Max. flow rate (water) ℓ/min <sup>(3)</sup>	30	55	90

Note <sup>(3)</sup> : Except for water, the flow rate should be divided by  $\sqrt{\gamma}$  ( $\gamma$  : sp.gr., water (4°C) : 1).

The flow rate calculated by following formula

$$Q = Cv \frac{\sqrt{\Delta P}}{0.696 \sqrt{\gamma}}$$

Where  $\Delta P$  : Differential pressure (kPa)

The rated flow shall be smaller between Cv calculation and maximum flow rate which is based on 2.5m/s.

## Construction

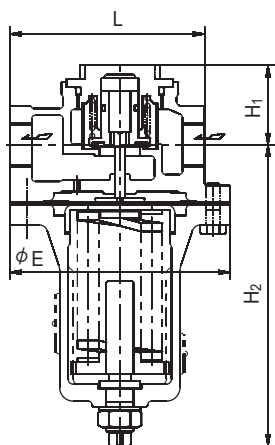

Body : Bronze

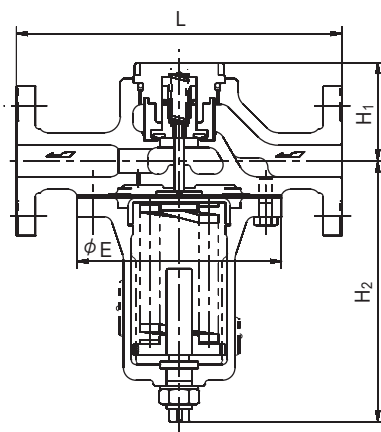

Body : Stainless cast steel

## Dimensions and weights

(mm, kg)

Material Connection	Size	Dimensions				Weight
		L	H <sub>1</sub>	H <sub>2</sub>	E	
Bronze Screwed	15	85	43	131	100	2.8
	20	115	47	178	130	5.5
	25	115	47	178	130	5.5
Stainless cast steel Flanged JIS10K	15	207	63	166	130	8.3
	20	211	63	166	130	8.7
	25	211	63	166	130	9.3

## Type PPD41B-2 Pressure Reducing Valves

### Sizing

Use the following chart to select the suitable valve size.

When viscosity is over 20mm<sup>2</sup>/s, flow rate should be corrected.

In the event that the inlet pressure or the outlet pressure is not constant but stays within range, select the minimum difference in pressure between the inlet pressure and outlet pressure to choose the correct size.

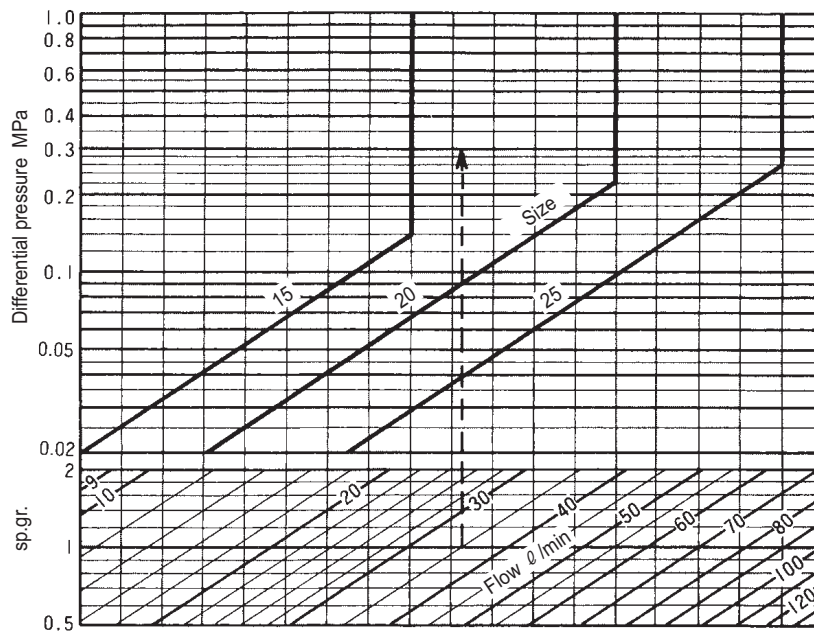

### Example

Fluid : Water  
Specific gravity : 1  
Inlet pressure : 0.5MPa  
Outlet pressure : 0.2MPa  
Flow : 35 l/min

Differential pressure : 0.7 - 0.1 = 0.6MPa

From intersecting point of 1 specific gravity line and 35 l/min flow line, draw a vertical line upward to 0.3MPa differential pressure line.

The final intersecting point is between size 15 line and size 20 line.

The required valve size is 20.

### Correction by viscosity

Correct the flow rate by the following formula.

$$\textcircled{1} \quad C_v = \frac{0.696Q\sqrt{\gamma}}{\sqrt{\Delta P}} \left\{ C_v = \frac{0.022Q\sqrt{\gamma}}{\sqrt{\Delta P}} \right\}$$

Where Q : Flow l/min

$\Delta P$  : Differential pressure kPa {MPa}

$\gamma$  : Specific gravity (water : 1)

$$\textcircled{2} \quad R = \frac{2642 \times Q}{\sqrt{C_v} \times \text{Viscosity at operating temperature mm}^2/\text{s}}$$

$\textcircled{3}$  Then obtain correction factor  $\alpha$  from the graph using factor R.  
Corrected Q = Q  $\times$   $\alpha$

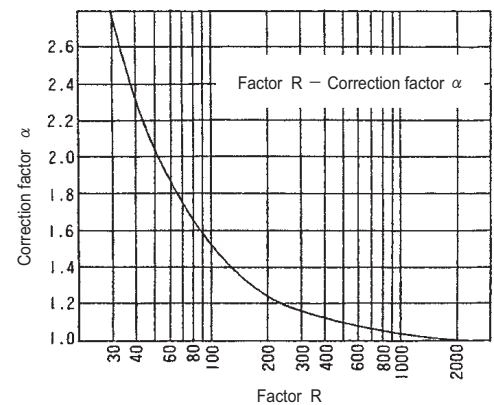

### Installation example

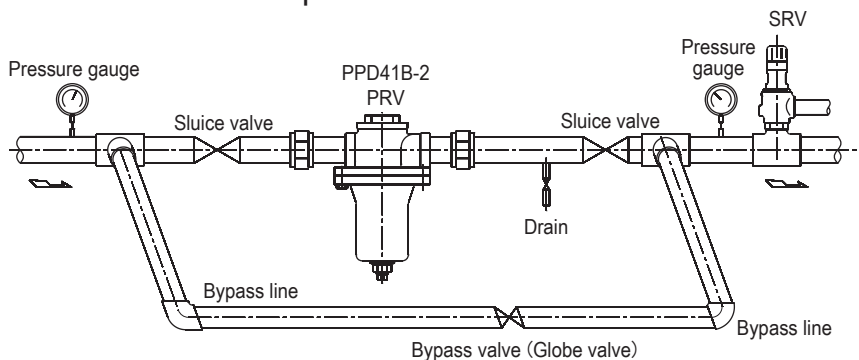

Note : Install upside-down in horizontal piping.