

Direct acting

Type PMD31 Pressure Reducing Valves

For liquid

- Stable operation
- Negligible influence is exerted by inlet pressure change due to the use of a pressure balancing construction.
- A valve disc made of synthetic rubber prevents seat leakage
- Use PPD41B-2 or PPD48 (F) pressure reducing valve for size 25 and smaller with small flow rate.



1 Pressure Reducing Valves (For liquid)

Specifications

Fluid	Size	Pressure (MPa)		Temp. (°C)	Material for main parts				Connection
		Inlet	Outlet set range		Body & spring case	Valve disc & diaphragm	Valve seat, liner & bush	Stem	
Water & non-corrosive liquid	15-80	0.055 1.0	0.035-0.3 0.2 -0.7	0 80	Cast iron (1)	Synthetic rubber	Bronze	Synthetic rubber	Flanged JIS10KFF
	100		0.035-0.3 0.2 -0.55						
	125 · 150		0.035-0.4						

Note (1) : For water lower than 60°C, rust-proof paint is applied for water contact surface.

- Remarks
1. Cast iron body is not suitable for drinking water.
 2. Cast steel body and stainless cast steel body are available on request.
 3. Non-copper alloy for fluid contact is available.
 4. ASME flange is available.

Performance

Min. differential pressure	0.02MPa
Offset pressure	10% of max. set range (min. 0.05MPa) or less
Lockup Pressure	0.01 - 0.02MPa
Min. controllable flow rate (water) (2)	3 - 5 ℓ /min
Seat leakage	Nil
Max. usable viscosity	200mm ² /s (at operating temp.) (3)

Note (2) : Except for water, the flow rate should be divided by $\sqrt{\gamma}$ (γ : sp.gr., water (4°C) : 1).

(3) : Available up to 400mm²/s upon request.

Flow characteristic curve

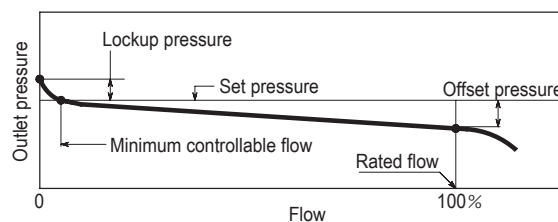

Cv values

Size	15	20	25	32	40	50	65	80	100	125	150
Cv	1.8	2.6	3.9	6.3	8.3	13	21	29	50	76	109

Remark : For viscosity above 200mm²/s and under 400mm²/s, Cv values are half above table.

Type PMD31 Pressure Reducing Valves

Pressure Reducing Valves (For liquid)

Sizing

Use the following chart to select the suitable valve size.

When viscosity over 20mm²/s, flow rate should be corrected.

In the event that the inlet pressure or the outlet pressure is not constant but stays within range, select the minimum difference in pressure between the inlet pressure and outlet pressure to choose the correct size.

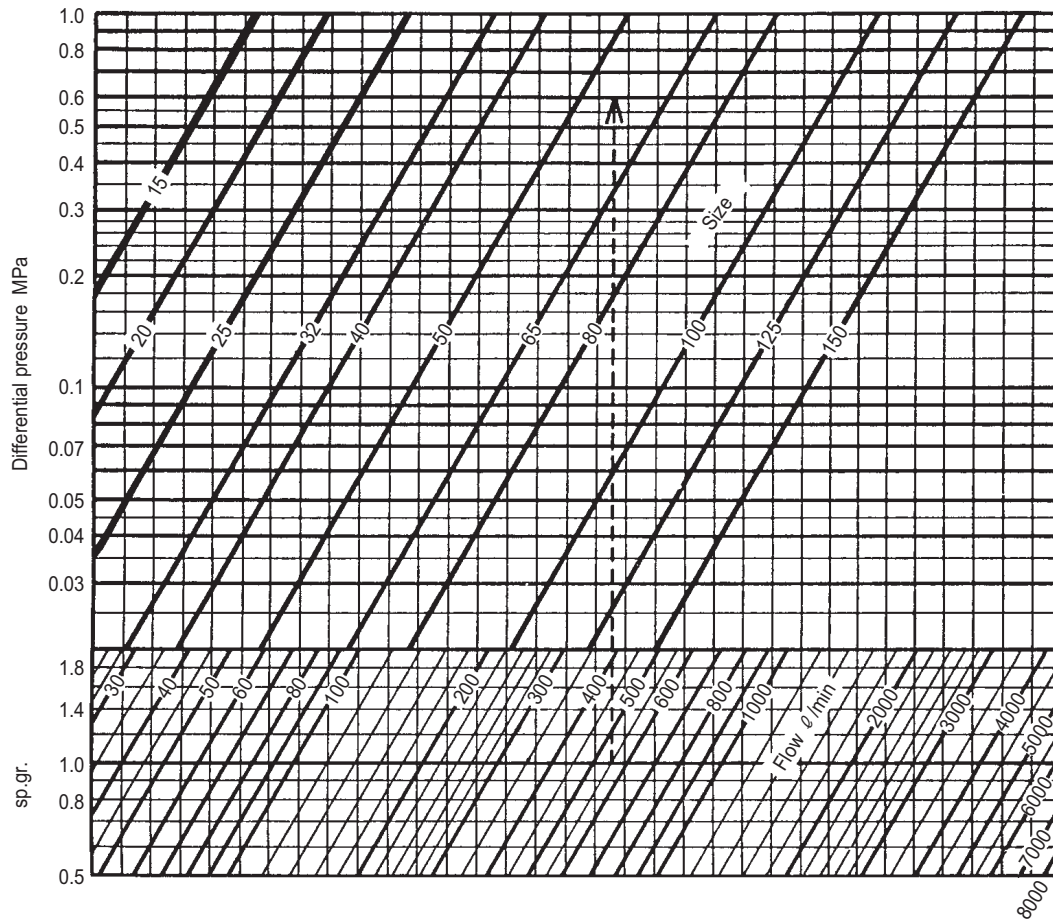

Example

Fluid : Water
Specific gravity : 1
Inlet pressure : 0.7MPa
Outlet pressure : 0.1MPa
Flow : 550 ℓ /min

Differential pressure :
0.7 - 0.1 = 0.6MPa

From intersecting point of 1.0 specific gravity line and 550 ℓ /min flow line, draw a vertical line upward to 0.6MPa differential pressure line.

The final intersecting point is between size 50 line and size 65 line.

The required valve size is 65.

Correction by viscosity

Correct the flow rate by the following formula.

$$① \quad C_v = \frac{0.696Q \sqrt{\gamma}}{\sqrt{\Delta P}} \quad \left\{ \quad C_v = \frac{0.022Q \sqrt{\gamma}}{\sqrt{\Delta P}} \quad \right\}$$

Where Q : Flow ℓ /min

ΔP : Differential pressure kPa {MPa}

γ : Specific gravity (water : 1)

$$② \quad R = \frac{2642 \times Q}{\sqrt{C_v} \times \text{Viscosity at operating temperature mm}^2/\text{s}}$$

③ Then obtain correction factor α from the graph using factor R.

Corrected Q = Q × α

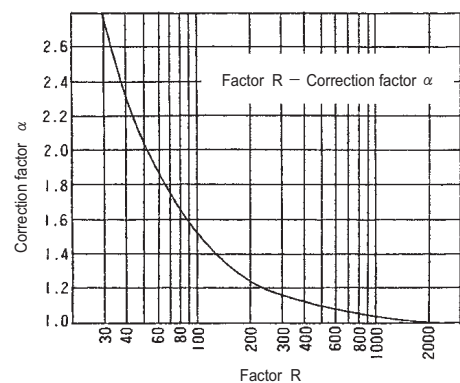

Type PMD31 Pressure Reducing Valves

1 Pressure Reducing Valves (For liquid)

Construction & Dimensions

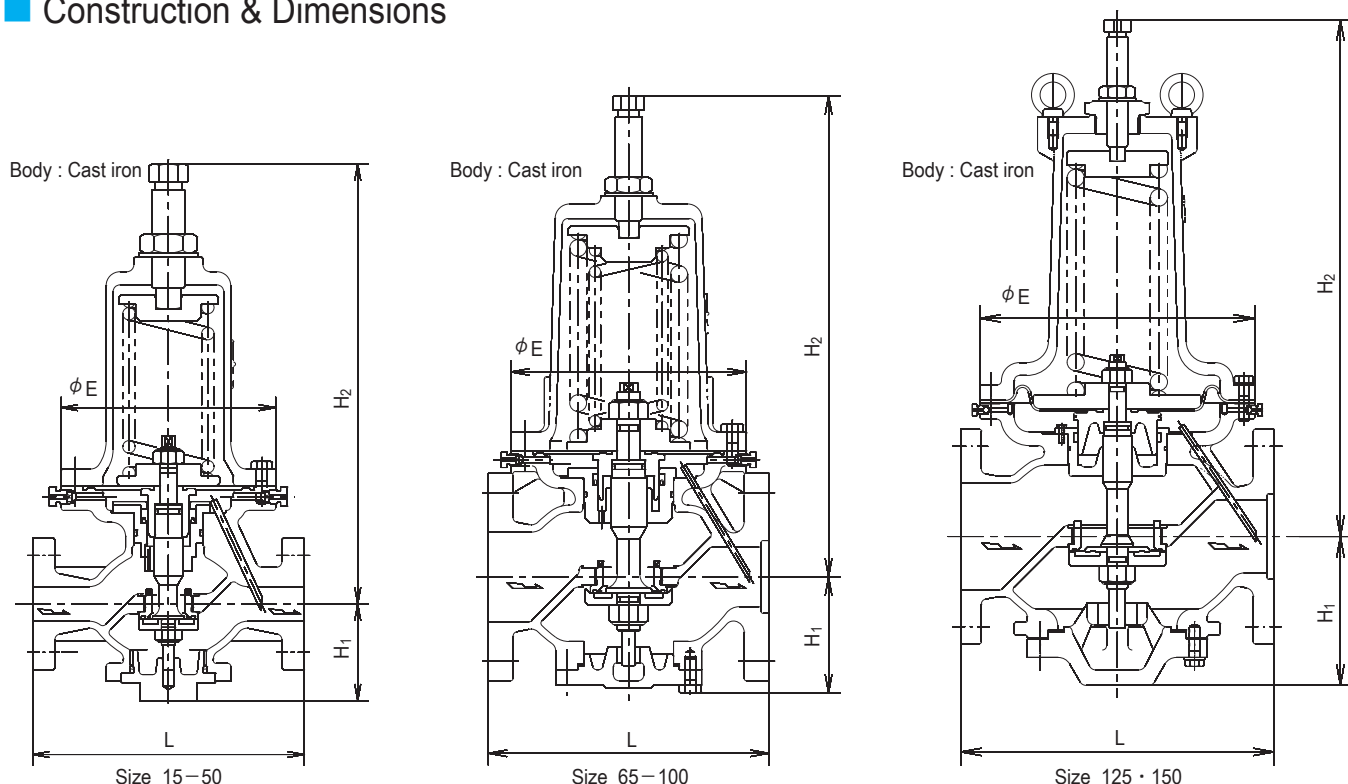

Dimensions and weights

(mm, kg)

Size	Body : Cast iron JIS10KFF					Body : Cast steel or Stainless cast steel JIS10KFF				
	L	H ₁	H ₂	E	Weight	L	H ₁	H ₂	E	Weight
15	196	70	318	155	12	206	70	318	155	16
20 · 25	200	70	318	155	13	210	70	318	155	17
32	175	70	318	155	14	220	70	318	155	18
40	190	80	328	155	16	220	80	328	155	21
50	195	80	328	155	17	225	80	328	155	22
65	230	104	429	210	34	280	109	429	210	38
80	250	104	429	210	35	280	109	429	210	39
100	290	127	466	250	58	330	121	471	250	65
125	365	174	612	320	98	380	174	612	320	114
150	415	207	792	380	159	470	207	792	380	170

Installation example

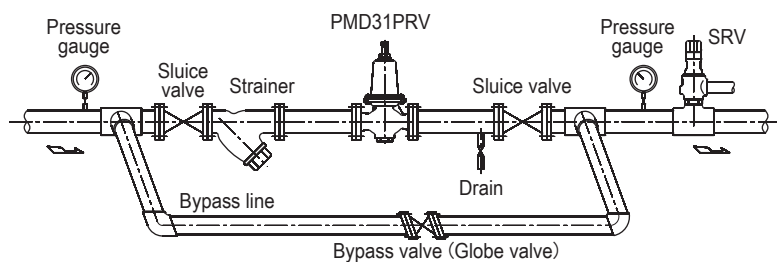

Space required for disassembling and maintenance (mm)

Size	Above the center of pipe line	Beneath the center of pipe line
15-32	470	190
40 · 50	480	200
65 · 80	590	340
100	650	400
125	930	450
150	1220	550

- Note
- PMD31 can be installed in both horizontal and vertical piping, however, in the case of hot water flowing from the top to the bottom, installation is not possible.
 - It is recommended that straight pipe lines of at least 400mm in length (for sizes 15-25), 600mm (for sizes 32 & 40), 900mm (for sizes 50 to 100) and 1200mm (for sizes 125 & 150) are provided in front of and behind the PMD31.