

Direct acting

Type PRL Pressure Reducing Valves

For gas

- For low pressure and large flow (size 65 – 150)
- Use PLG61-2 or PMD31L pressure reducing valve for small flow rate (size 15 – 50).



1 Pressure Reducing Valves (For gas)

Specifications

Fluid	Size	Pressure (kPa)		Temp. (°C)	Material for main parts			Connection
		Inlet	Outlet set range		Body	Valve disc & seat	Diaphragm	
Air & non-corrosive gases	65 – 150	500 or less ⁽¹⁾	1.0 – 50 ⁽¹⁾	0 – 80	Cast iron	Stainless steel	Synthetic rubber	Flanged JIS10KFF

 Note ⁽¹⁾: Refer to following table of "Outlet set pressure range and top-work model".

- Remarks
1. Cast steel body and stainless cast steel body are available on request.
 2. ASME flange is available.

Outlet set pressure range and top-work model

Size	Top-work & max. differential pressure (kPa)	Outlet set pressure (kPa)	1.0 or over	over 1.5	over 2.0	over 3.0	over 5.0	over 7.0	over 10	over 15	over 20	over 30
			1.5	2.0	3.0	5.0	7.0	10	15	20	30	50
65	Top-work model		A	B	B	B	C	C	D	D	E	E
	Max. ΔP		150	130	200	340	300	430	420	500	500	500
80	Top-work model		A	A	B	B	B	C	D	D	D	E
	Max. ΔP		140	180	180	290	410	380	370	490	500	500
100	Top-work model		A	A	A	B	B	C	C	C	D	D
	Max. ΔP		110	140	220	240	330	300	460	500	500	500
125	Top-work model		A	A	A	A	A	B	C	C	D	D
	Max. ΔP		84	110	170	280	390	360	350	470	460	480
150	Top-work model		A	A	A	A	A	B	C	C	D	D
	Max. ΔP		68	90	140	230	310	290	280	380	370	390

Remark: Maximum allowable pressure for valve inlet is outlet set pressure + maximum ΔP.

Example: In case of size: 100 and set press.: 10kPa, max. allowable pressure is 300 + 10 = 310kPa.

Performance

Range ability	Depend on set pressure and top-work model
Offset pressure	12% of max. set range or less
Min. controllable flow (air)	5% of rated flow
Seat leakage	0.5% of rated flow or less

Cv values

Size	65	80	100	125	150
Cv	35	46	72	123	178

Type PRL Pressure Reducing Valves

Pressure Reducing Valves (For gas)

1

■ Sizing

Select the suitable size by Cv calculation.

In case of $(P_1 - P_2) \leq \frac{P_1}{2}$	In case of $(P_1 - P_2) \geq \frac{P_1}{2}$	Description
$Cv = \frac{V}{3.94} \sqrt{\frac{G(273+t)}{(P_1 - P_2)P_2}} \quad - (1)$	$Cv = \frac{V\sqrt{G(273+t)}}{1.97P_1} \quad - (2)$	V : Flow rate m ³ /h (normal) G : Specific gravity (air : 1) T : Temperature °C P ₁ : Inlet pressure MPa abs P ₂ : Set pressure MPa abs
In case of amb. temp (20°C)		
$Cv = \frac{V}{0.23} \sqrt{\frac{G}{(P_1 - P_2)P_2}} \quad - (3)$	$Cv = \frac{V\sqrt{G}}{0.115P_1} \quad - (4)$	

Example
 Fluid : Air
 Temperature : 40°C
 P₁ : 200kPa
 P₂ : 5.0kPa
 Flow : 1300m³/h (normal)

P₁ = 301.3kPa abs
 P₂ = 106.3kPa abs
 $P_1 - P_2 = 195 > \frac{1}{2} P_1 = 150.65$
 Cv = 38.8 (Calculate by formula (2))
 Required valve size is 80 (Cv : 46)

■ Construction

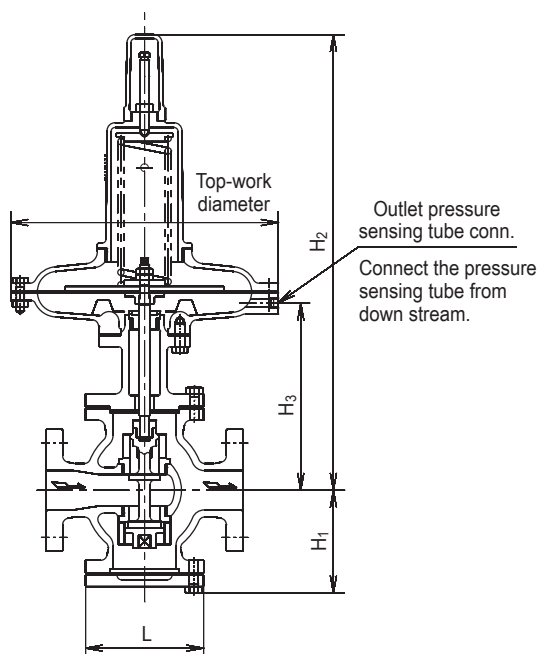

Dimensions and weights

Size	65	80	100	125	150
L	240	270	310	360	380
H ₁	143	147	175	205	224
H ₂	590	602	630	675	694
H ₃	248	260	288	333	352
Weights ⁽²⁾	57	65	81	104	122

Note ⁽²⁾ : In case of top-work C.

Top-work diameter

Model	A	B	C	D	E
Diameter	610	500	410	340	290
Weight fluctuation ⁽³⁾	+27	+12	0	-7	-10

Note ⁽³⁾ : Based on top-work C.

■ Installation example

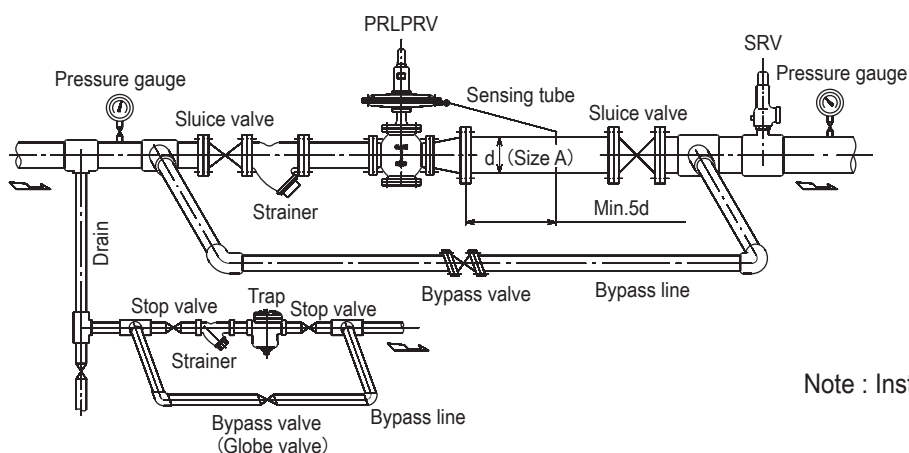

Note : Install in horizontal piping.