

Direct acting

# Type PPD41L-2 Pressure Reducing Valves

For gas

- For low pressure use of PPD41B-2 pressure reducing valve.
- A valve disc made of synthetic rubber prevents seat leakage.
- A strainer is built in stainless cast steel body valve.
- Use PMD31L pressure reducing valve for larger flow rate.

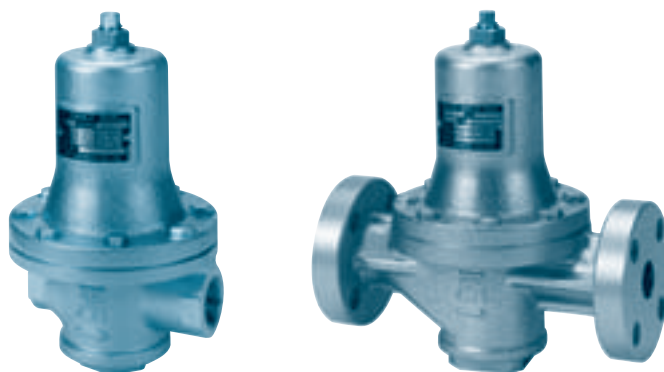

1 Pressure Reducing Valves (For gas)

## Specifications

Fluid	Pressure (MPa)		Max. Temp. (°C)	Material for main parts					Connection
	Inlet	Outlet set range		Body	Bottom cover	Spring case	Valve disc	Diaphragm	
Air & non-corrosive gases	0.03   0.5	0.01-0.05 0.03-0.15	0   80	Cast iron	Bronze	Cast iron	Stainless steel & synthetic rubber	Synthetic rubber	JIS Rc Screwed
				Cast iron	Bronze				Flanged JIS10KFF
				Cast steel	Stainless steel				
				Stainless cast steel					

## Performance

Min. differential pressure	0.02MPa
Offset pressure	Approx. 10% of max. set range
Lockup Pressure	Approx. 5% of max. set range
Min. controllable flow (air)	Approx. 0.3m³/h (normal)
Seat leakage	Nil
Cv	1.8
Max. flow	Size 15 : 20m³/h (normal) Size 20, 25 : 35m³/h (normal)

Flow characteristic curve

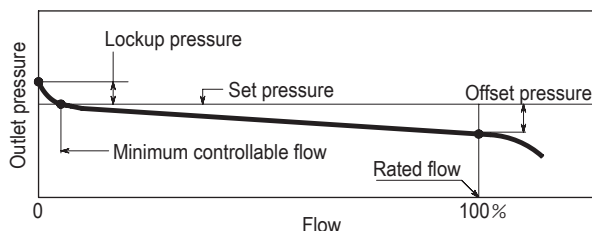

## Construction

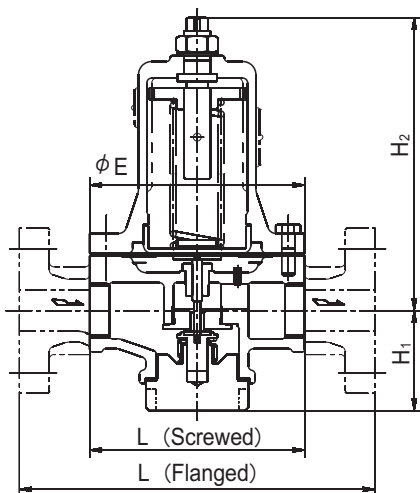

Dimensions and weights

(mm, kg)

Body	Size	Dimensions				Weights	Connection
		L	H <sub>1</sub>	H <sub>2</sub>	E		
Cast iron	15	95	49	128	100	2.6	JIS Rc Screwed
	20	130	61	178	130	5.8	
	25	130	61	178	130	5.8	
Cast iron	15	170	54	124	100	4.6	Flanged JIS10KFF
	20	215	65	173	130	7.9	
	25	215	65	173	130	8.9	
Cast steel	15	207	69	169	130	8.3	Flanged JIS10KFF
	20	211	69	169	130	8.7	
	25	211	69	169	130	9.3	
Stainless cast steel	15	207	63	166	130	8.3	Flanged JIS10KFF
	20	211	63	166	130	8.7	
	25	211	63	166	130	9.3	