

Direct acting

Type RMD31 Back Pressure Regulating Valves

For liquid

- Negligible influence is exerted by outlet pressure change due to the use of a pressure balancing construction.
- A valve disc made of synthetic rubber prevents seat leakage

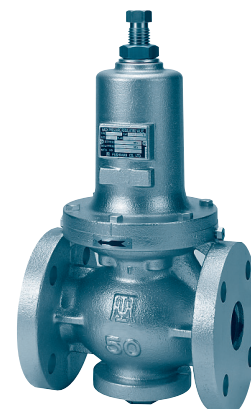

2 Pressure Regulating Valves (For liquid)

Specifications

Fluid	Size	Inlet set pressure range (MPa)	Temp. (°C)	Material for main parts				Connection
				Body & spring case	Valve disc & diaphragm	Valve seat, liner & bush	Stem	
Water & non-corrosive liquid	15-80	0.035-0.3 0.2 -0.7	0 80	Cast iron ⁽¹⁾	Synthetic rubber	Bronze	Synthetic rubber	Flanged JIS10KFF
	100	0.035-0.3 0.2 -0.55						
	125-150	0.035-0.4						

Note ⁽¹⁾ : For water lower than 60°C, rust-proof paint is applied for water contact surface.

- Remarks
1. Cast steel body and stainless cast steel body are available on request
 2. Non-copper alloy for fluid contact is available.

Performance

Min. differential pressure	0.02MPa
Offset pressure	0.06MPa (for size 15-40, 65, 125, 150) 0.08MPa (for size 50, 80, 100)
Dead-end shut off pressure	0.01-0.02MPa
Min. controllable flow rate (water) ⁽²⁾	3-5 ℓ/min
Seat leakage	Nil
Max. usable viscosity	400mm ² /s (at operating temp.)

Note ⁽²⁾ : Except for water, the flow rate should be divided by $\sqrt{\gamma}$ (γ : sp.gr., water (4°C): 1).

Flow characteristic curve

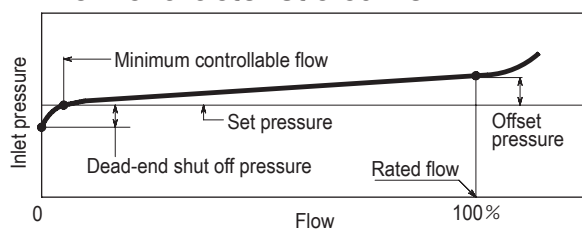

Cv values

Size	15-25	32	40	50	65	80	100	125	150
Cv	3.9	6.3	8.3	13	21	29	50	76	109
Max. flow rate (water) ℓ/min ⁽³⁾	90	150	204	330	543	767	1323	2016	2892

Note ⁽³⁾ : Except for water, the flow rate should be divided by $\sqrt{\gamma}$ (γ : sp.gr., water (4°C): 1).

The flow rate is calculated by following formula

$$Q = Cv \frac{\sqrt{\Delta P}}{0.022 \sqrt{\gamma}} \quad \ell/\text{min}$$

Where ΔP : Differential pressure (MPa)

The rated flow shall be smaller between Cv calculation and maximum flow rate which is based on 2.5m/s.

Dimensions and weight

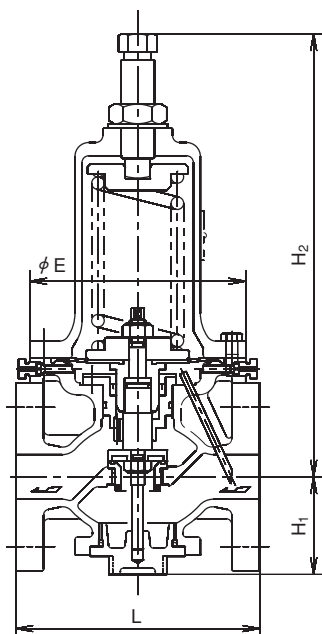

Dimensions and weights

(mm, kg)

Size	Body : Cast iron JIS10KFF					Body : Cast steel or Stainless cast steel JIS10KFF				
	L	H ₁	H ₂	E	Weight	L	H ₁	H ₂	E	Weight
15	196	70	317	155	12	206	70	317	155	16
20	200	70	317	155	13	210	70	317	155	17
25	200	70	317	155	13	210	70	317	155	17
32	175	70	317	155	14	220	70	317	155	18
40	190	80	325	155	16	220	80	325	155	21
50	195	80	325	155	17	225	80	325	155	22
65	230	104	425	210	34	280	109	425	210	38
80	250	104	425	210	35	280	109	425	210	39
100	290	127	460	250	58	330	121	465	250	65
125	365	174	607	320	98	380	174	607	320	114
150	415	207	787	380	159	470	207	787	380	170

Type RMD31 Back Pressure Regulating Valves

Sizing

Use the following chart to select the suitable valve size.

In the event that the inlet pressure or the outlet pressure is not constant but stays within range, select the minimum difference in pressure between the inlet pressure and outlet pressure to choose the correct size.

Example

Fluid : Water

Specific gravity : 1

Inlet set pressure : 0.3MPa

Flow : 400 ℓ/min

From intersecting point of 1.0 specific gravity line and 400 ℓ/min flow line, draw a vertical line upward to differential pressure 0.3 – 0 = 0.3MPa line.

The final intersecting point is between size 50 line and size 65 line.

The required valve size is 65.

Correction by viscosity

Correct the flow rate by the following formula.

$$① \quad C_v = \frac{0.022Q\sqrt{\gamma}}{\sqrt{\Delta P}}$$

Where Q : Flow ℓ/min

ΔP : Differential pressure MPa

γ : Specific gravity (water : 1)

$$② \quad R = \frac{2462 \times Q}{\sqrt{C_v \times \text{Viscosity at operating temperature mm}^2/\text{s}}}$$

③ Then obtain correction factor α from the graph using factor R.

$$\text{Corrected } Q = Q \times \alpha$$

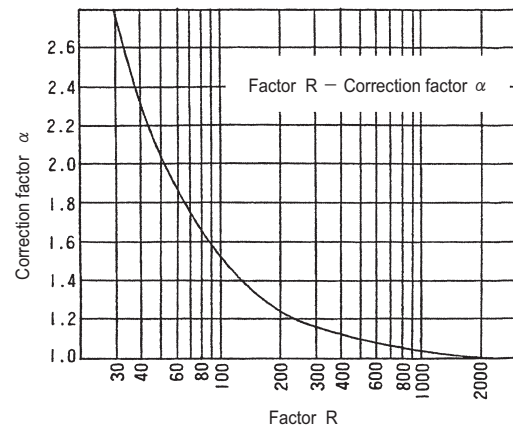
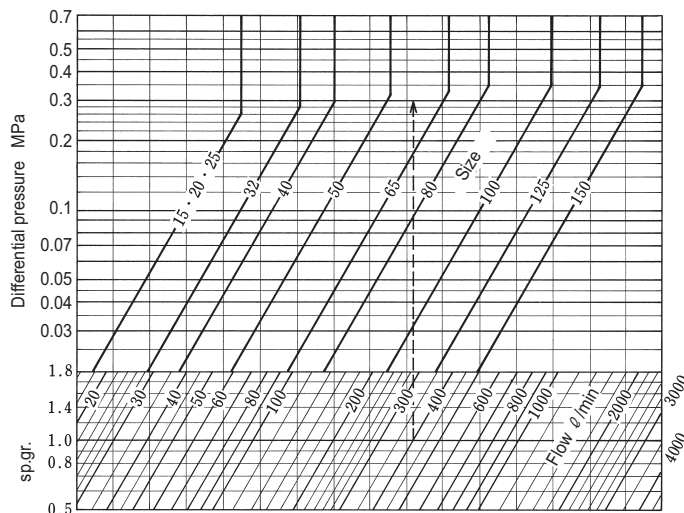

Space required for disassembling and maintenance

Size	15-32	40 · 50	65 · 80	100	125	150
Above the center of pipe line	470	480	640	730	930	1220

Installation example

Note 1. RMD31 can be installed in both horizontal and vertical piping, however, in the case of hot water flowing from the top to the bottom, installation is not possible.

2. It is recommended that straight pipe lines of at least 300mm in length (for 15-25), 600mm (for sizes 32 & 40), 900mm (for sizes 50 to 100) and 1200mm (for sizes 125 & 150) are provided in front of and behind the RMD31.

