

**Direct acting**

# Type BRL Back Pressure Regulating Valves

**For gas**

- For low pressure and large flow (size 65–50)
- Use RLG61-2 or RMD31L back pressure regulating valve for small flow rate (size 15–50).

**2 Back Pressure Regulating Valves (For gas)**

## Specifications

Fluid	Size	Inlet set pressure range (kPa)	Temp (°C)	Material for main parts			Connection
				Body	Valve disc & seat	Diaphragm	
Air & non-corrosive gases	65–150	1.0–50 (1)	0–80	Cast iron	Stainless steel	Synthetic rubber	Flanged JIS10KFF

Note (1) : Refer to following table o "Inlet set pressure range and top-work model".

Remark : Cast steel body and stainless cast steel body are available on request.

### Inlet set pressure range and top-work model

Set press.range kPa	Size										
	1.0 or over	1over 1.5	over 2.0	over 3.0	over 5.0	over 7.0	over 10	over 15	over 20	over 30	over 30
Size	1.5	2.0	3.0	5.0	7.0	10	15	20	30	50	50
65	A	B	C	C	D	D	D	E	E	E	E
80	A	B	B	C	C	D	D	D	E	E	E
100	A	A	B	B	C	C	D	D	D	E	E
125	A	A	A	B	B	C	C	D	D	D	D
150	A	A	A	A	B	B	C	C	D	D	D

## Performance

Offset	12% of max. set range or less
Min. controllable flow (air)	5% of rated flow
Seat leakage	0.5% of rated flow or less

## Cv values

Size	65	80	100	125	150
Cv	35	46	72	123	178

## Sizing

Equation	Description
$C_v = \frac{V}{3.94} \sqrt{\frac{G(273+t)}{(P_1 - P_2)P_2}} \quad - (1)$	V : Flow rate m <sup>3</sup> /h (normal) G : Specific gravity (air : 1) t : Temperature °C P <sub>1</sub> : Inlet set pressure kPa abs P <sub>2</sub> : Outlet pressure kPa abs
At amb. temp. (20°C)	
$C_v = \frac{V}{0.23} \sqrt{\frac{G}{(P_1 - P_2)P_2}} \quad - (2)$	

### Example

 Fluid : CO<sub>2</sub> (Molecular weight : 44)

Temperature : 70°C

Inlet set pressure : 5.0kPa

Outlet pressure : Atmospheric.

 Flow : 250m<sup>3</sup>/h (normal)

 $P_1 = 5 + 101.3 = 106.3 \quad P_2 = 101.3$ 
 $P_1 - P_2 = 5.0$ 
 $C_v = 64.4$  (Calculate by formula (1))

Required valve size is 100 (Cv : 72)

# Type BRL Back Pressure Regulating Valves

## Construction

2

Back Pressure Regulating Valves (For gas)

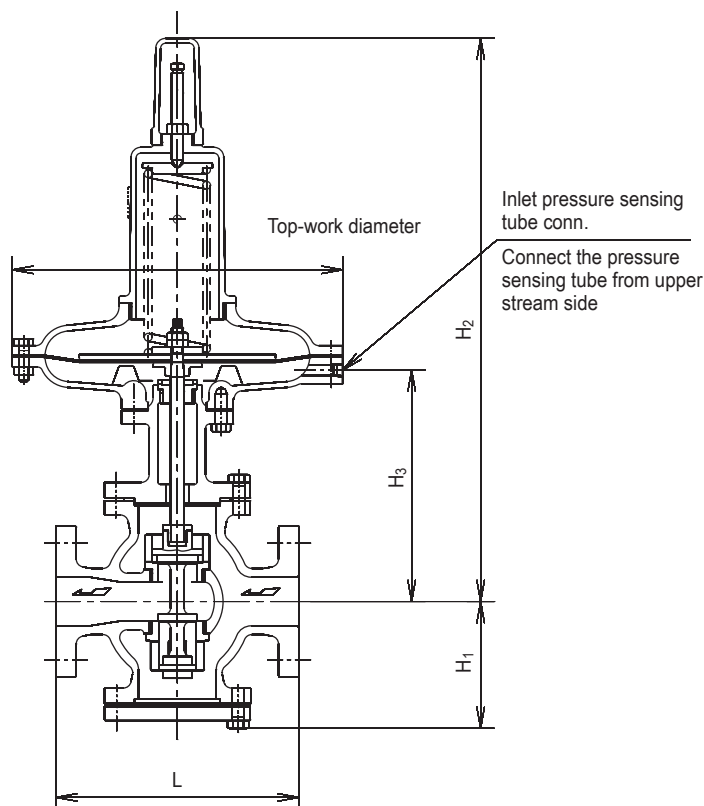

Dimensions and weights. (mm, kg)

Size	65	80	100	125	150
L	240	270	310	360	380
H <sub>1</sub>	143	147	175	205	224
H <sub>2</sub>	590	602	630	675	694
H <sub>3</sub>	248	260	288	333	352
Weights <sup>(2)</sup>	57	65	81	104	122

Note <sup>(2)</sup> : In case of top-work C.

Top-work diameter (mm, kg)

Model	A	B	C	D	E
Diameter	610	500	410	340	290
Weight fluctuation <sup>(3)</sup>	+27	+12	0	-7	-10

Note <sup>(3)</sup> : Based on top-work C.

## Installation example

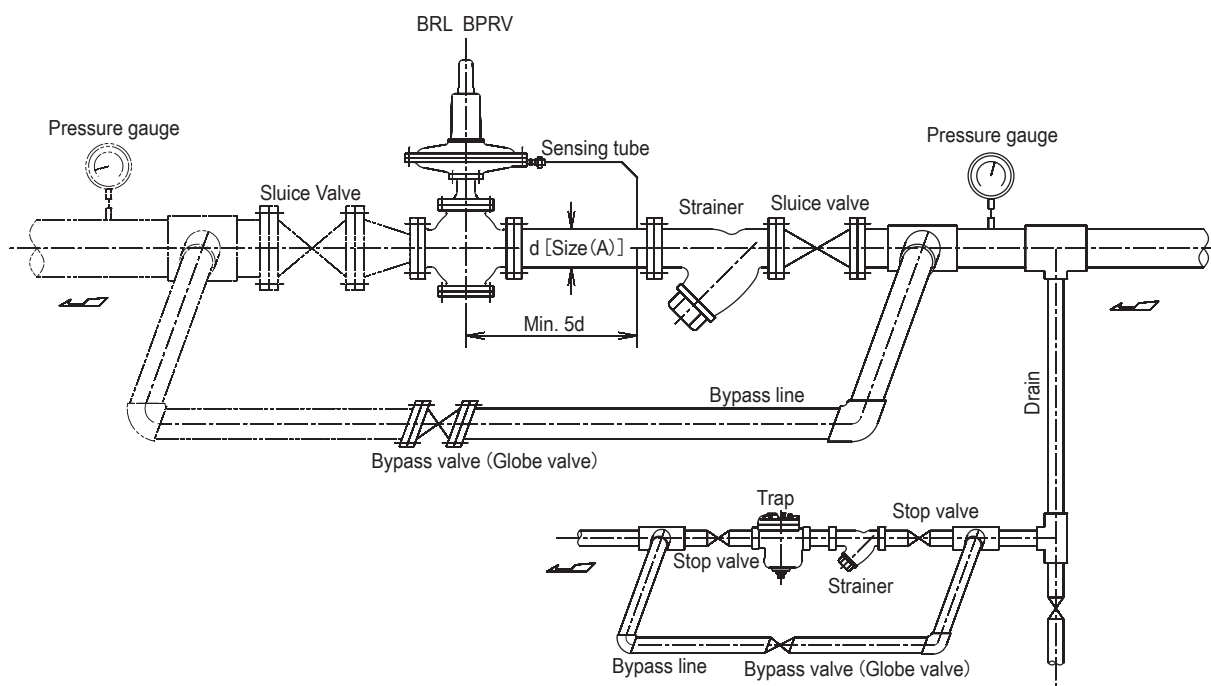

Note : Install upright in horizontal piping.